

USER MANUAL

(Version 02-2023)

Level Gauges SNA | SNK | SNKK



Temperature Sensors TS-SNA/SNK-...



CONTRIBUTING TO **YOUR SUCCESS**



CONTENT

- 1. GENERAL INFORMATION 3
 - Applications 3
 - Installation requirements 3
- NOTE: 4
 - Figure 1: Correct Installation of gasket 4
 - Figure 2: surfaces slightly wetted with oil 4
 - Removing and re-installation 4
- 2. PROPERTIES OF THE MODULAR PRINCIPLE 5
 - Technical Data 5
 - Materials 5
 - Characteristics 5
 - Options & Accessories 5
 - Custom Solutions 5
- 3. LEVEL GAUGES SNA 6
 - Dimensions 6
 - Ordering Information 6
- 4. LEVEL GAUGES SNK 7
 - Dimensions 7
 - Electrical Functions 7
 - Ordering Information 8
- 5. LEVEL GAUGES SNKK (Compact Design) 9
 - Dimensions 9
 - Electrical Functions 9
 - Ordering Information 10
- 6. TEMPERATURE SENSOR TS-SNA/SNK-PT100 11
 - Dimensions 11
 - Electrical Functions 11
 - Ordering Information 12
- 7. THERMO SWITCH TS 13
 - Dimensions 13
 - Electrical Functions 13
 - Ordering Information 14

1. GENERAL INFORMATION

Applications

STAUFF level gauges SNA/SNK/SNKK have been designed for the visual / electrical fluid level indication for all kinds of reservoirs. STAUFF level gauges can be used in stationary and mobile hydraulic applications. By owning a IP65 protection, the modular principle of STAUFF level gauges covers a wide range like indoor, outdoor, or marine applications. STAUFF level gauges can be used at temperatures from -30°C to +80°C [-22°F...+176°F].

It is recommended to check chemical compatibility between the fluid and the level gauge respectively seals prior installation and use. Therefore, the name of the fluid and the process temperatures are minimum requirements to request this information at STAUFF.

Installation requirements

STAUFF level gauges must be fitted vertically to one of the reservoirs walls.
The maximum wall thickness is 8mm

The surface of the reservoir must be smooth and without welding beads on the sealing surface or burrs on the bore. For the contact surface of the seal (min. Ø22mm) a surface roughness of Ra 3.2 is required for a reliable sealing function.

The reservoir surface should be smooth and without burr at the sealing surface.

The sealing surface shouldn't be painted or just painted if it is for sure that the paint is resistant against the fluid inside the reservoir. Otherwise, the paint will solute and could cause a leakage, as the paint layer is located between reservoir wall and gasket.

The flatness of the two mounting surfaces should be within a tolerance of 0,2mm.

Recommended max depth of a recessed area:

SNA: 1mm

SNK/SNKK: 4mm

Plastic reservoirs respectively reservoirs made from thin sheet metal should keep it shape even at vibration or pressurization. If such reservoirs will become bumpy, a second flat seal per banjo bolt might help to prevent leakage.

The deviation due to deformation shouldn't overcome 0,2mm up to a length of 150mm and 0,5mm for length over 150mm.

The wall thickness at reservoirs need to withstand torque requirements, vibration, pressurization, and aging effects.

Furthermore, reinforcement of the mounting surfaces should be provided to eliminate unevenness due to bulging, or due to welding distortion. For this purpose, stiffening plates should be provided with a weld seam on all sides.

A tightening torque of 8⁺2Nm is required to mount STAUFF level gauges.

NOTE:

STAUFF SNK and SNKK series cannot be mounted with the electrical connection at the top.

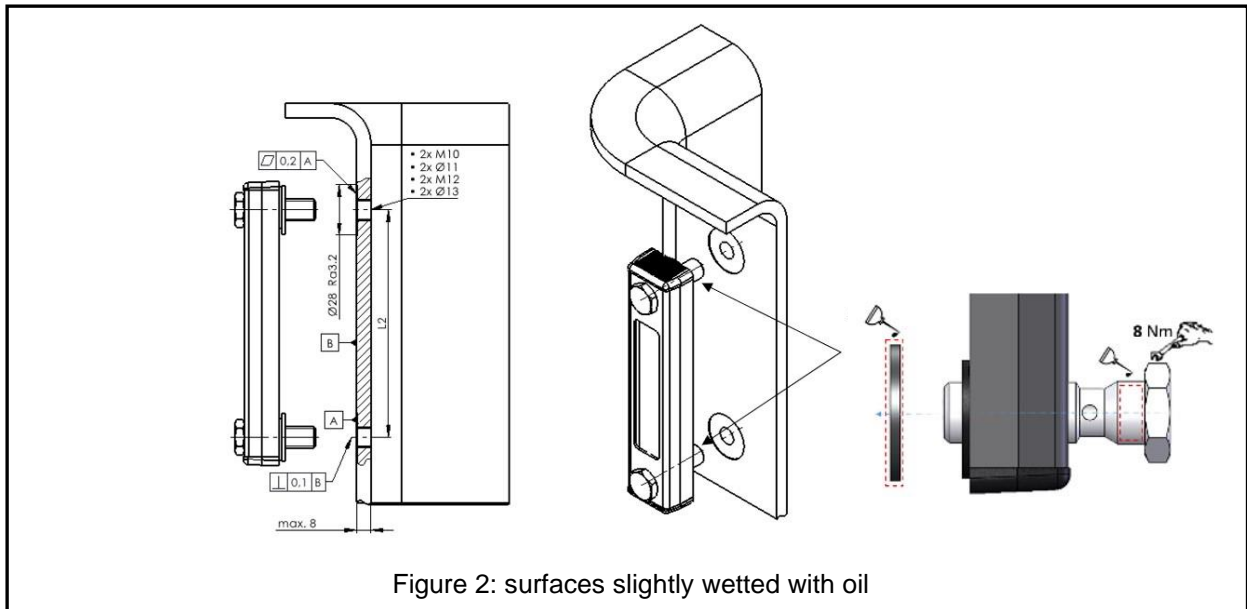
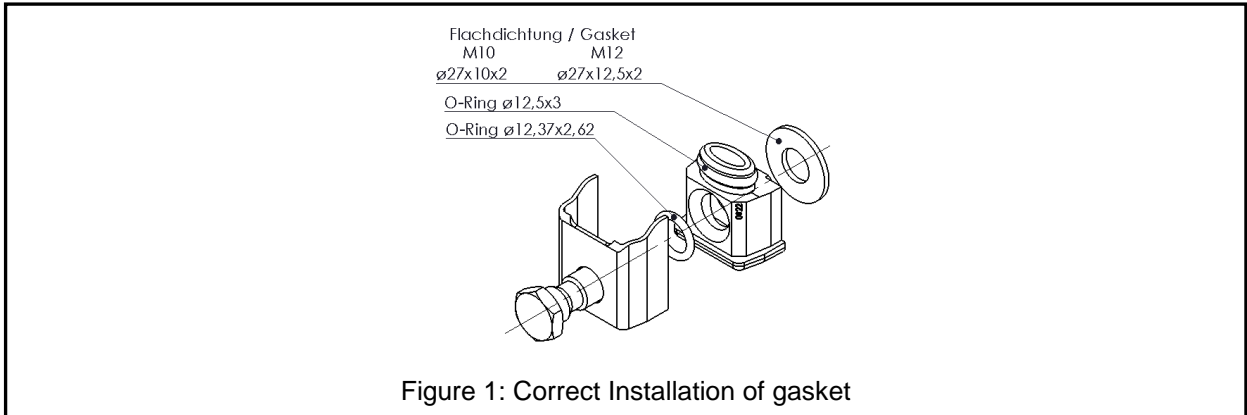

Removing and re-installation

If you need to remove a level gauge for any reason whatsoever, it is essential that you take note of the following information when mounting the device again:

- If the sight glass tube was opened it is mandatory to push both plugs inside the tube prior adding O-rings and the housing again. The O-rings of both plugs must be situated on the smooth interior surface of the sight glass. Push in plugs perpendicular to prevent damaging respectively cutting the O-ring. Leaks may occur if these are not correctly fitted!
- SNK/SNKK: The float inside the sight glass must be inserted with the magnet located inside the float pointing towards the reed contact at the bottom of the sight glass.

2. PROPERTIES OF THE MODULAR PRINCIPLE

Technical Data

Operating temperature range:	-30°C...80°C
Initial stress pressure of the reservoir:	max. 1bar
Lateral distance to other components:	min. 10mm
Protection class:	min. IP65

Materials

Housing:	ST or AL (epoxy coated)
Plugs, Sight Glass:	PA
Float:	PA

Characteristics

- Suitable for mineral oil based hydraulic oils
- Good UV resistance
- SNK are available as a break (n/c), make (n/o) contact. In addition, SNKK is available with changeover (SPDT) contact

Options & Accessories

Dial thermometer with probe	0°C...100°C
Temperature switch TS-SNA/SNK...	60°C / 70°C / 80°C
Temperature sensor TS-SNA/SNK-PT100	-40°C...150°C

Custom Solutions

- Increased chemical resistance is possible by using special materials. Please consult STAUFF if the level gauge is to be used with different fluids or under special operating conditions (e.g., temperatures, etc.)
- Special lengths can be provided, even at smaller quantities

3. LEVEL GAUGES SNA

Dimensions

Dial Thermometer with Probe T1/T2 (optional)

Clearance Hole:
 Ø13 (Ø.51) for M12 / Ø10,5 (Ø.41) for M10 /
 Ø13,5 (Ø.53) for UNC, UNF and UNEF

SNA	L1	L2	L3
076	108	76	31
127	159	127	76
150	182	150	99
176	208	176	124
254	286	254	192
305	337	305	244
381	413	381	319

Ordering Information

SNA-076-B-S-T-12-O-60/2-N-123456

Hyphen

STAUFF Level Gauge (GB) / STAUFF Niveaumanzeiger (GER)	STAUFF Special number (optional)
Product range Hydraulic Accessories	STAUFF Special number according to list "Special-Number-New"
SNA STAUFF Level Gauge	Additional information (optional)
STAUFF Group size	Colours according to list "Colours", special characteristics according to list "Characteristics"
STAUFF group size according to STAUFF ONE equals the distance between the centre of the two banjo bolts [in mm]	Design code (optional)
Seal material	Slash and design code value without a blank
Materials according to list "Materials"	Switching temperature (optional, only for Thermo Switch)
Design of Scale Plate	temperature value (in °C), two digits
S with STAUFF Logo	Thermo Switch / Temperature Sensor / Anti Drain valve (optional)
N neutral without any logo	without without switch, sensor or anti-drain valve
X customer-designed scale plate	O Thermo Switch, break contact (NO)
Thermometer Option	C Thermo Switch, make contact (NC)
O without thermometer	OD Thermo Switch, break contact (NO) with connector M12
T red capillary tube thermometer on the scaleplate	CD Thermo Switch, make contact (NC) with connector M12
TB blue capillary tube thermometer on the scaleplate	PT100 Thermo Switch PT100 with connector M12
T1C Dial thermometer, 200 mm probe, °C scale	DA Drainvalve Set A (one drain valve to be used with the lower banjo bolt)
T2C Dial thermometer, 300 mm probe, °C scale	DB Drainvalve Set B (two drain valves to be used with both banjo bolts)
T1CF Dial thermometer, 200 mm probe, °C and °F scale	Banjo Bolt size
T2CF Dial thermometer, 300 mm probe, °C and °F scale	12 banjo bolt thread M12
	10 banjo bolt thread M10
	U1 banjo bolt thread 1/2-13 UNF
	U2 banjo bolt thread 1/2-20 UNF
	U3 banjo bolt thread 1/2-28 UNF

4. LEVEL GAUGES SNK

Dimensions

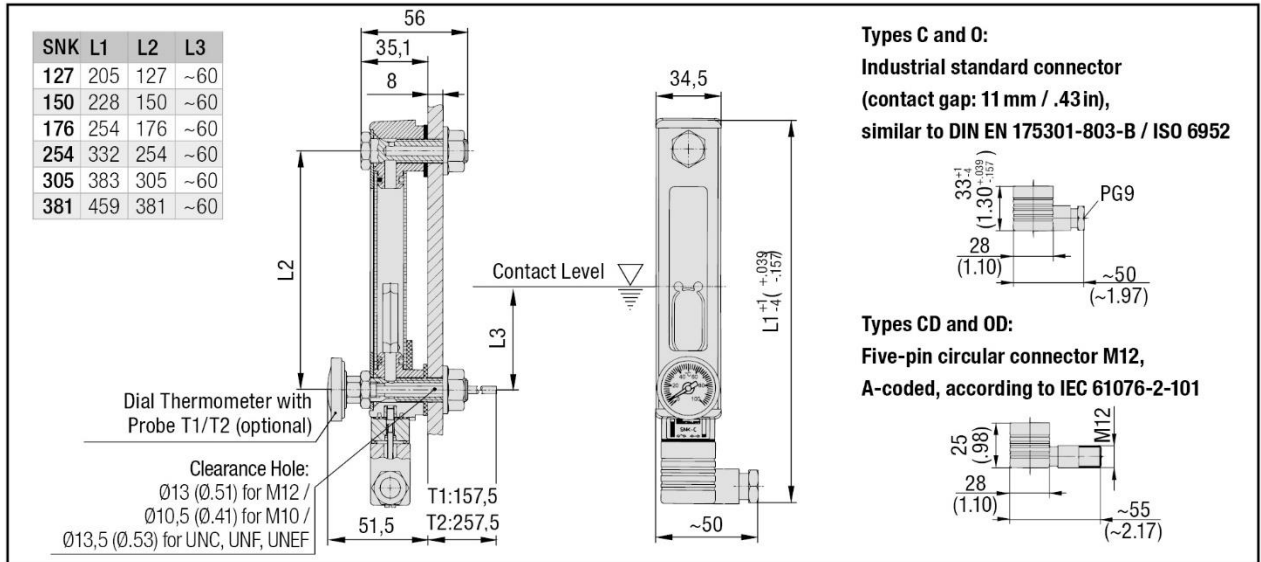
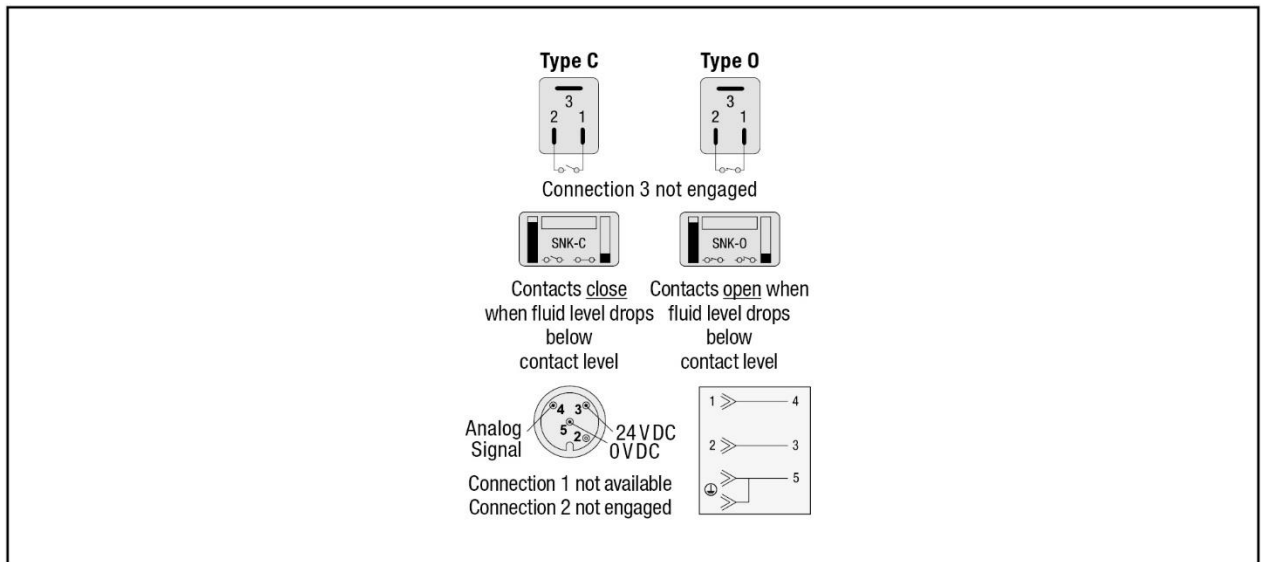

Table shows dimension L1 for the version with industrial standard connector (Types C and O) only.

Maximum admissible tolerance for the bolt center spacing (dimension L2) according to DIN ISO 2768-f: $\pm 0,20$ mm / .008 in for all nominal sizes.

Electrical Functions



Ordering Information

Hyphen

SNK-254-V-C-O-12-O-60/2-N-123456

STAUFF Level Gauge [GB] / STAUFF Niveaumanzeiger [GER]		STAUFF Special number (optional)	
Product range Hydraulic Accessories		STAUFF Special number according to list "Special-Number-New"	
SNK	STAUFF Level Gauge (electrical)		
SNK-52-...	STAUFF Level Gauge (electrical) with 2 contacts		
STAUFF Group size		Additional information (optional)	
STAUFF group size according to STAUFF ONE (equals the distance between the centre of the two banjo bolts [in mm])		Colours according to list "Colours", special characteristics according to list "Characteristics"	
Seal material		Design code (optional)	
Materials according to list "Materials"		Slash and design code value without a blank	
Electrical Function		Switching temperature (optional, only for Thermo Switch)	
O	Break contact (NO), standard connection	temperature value [in °C], two digits	
IC	Make contact (NC), standard connection		
OD	Break contact (NO) with connector M12		
CD	Make contact (NC) with connector M12		
Thermometer Option		Thermo Switch / Temperature Sensor / Anti Drain valve (optional)	
O	without thermometer	without	without switch, sensor or anti-drain valve
T1C	Dial thermometer, 200 mm probe, °C scale	O	Thermo Switch, break contact (NO)
T2C	Dial thermometer, 300 mm probe, °C scale	C	Thermo Switch, make contact (NC)
T1CF	Dial thermometer, 200 mm probe, °C and °F scale	CD	Thermo Switch, break contact (NO) with connector M12
T2CF	Dial thermometer, 300 mm probe, °C and °F scale	PT100	Thermo Switch PT100 with connector M12
		DA	Drainvalve Set A (one drain valve to be used with the lower banjo bolt)
		DB	Drainvalve Set B (two drain valves to be used with both banjo bolts)
		Banjo Bolt size	
		12	banjo bolt thread M12
		10	banjo bolt thread M10
		U1	banjo bolt thread 1/2-13 UNC
		U2	banjo bolt thread 1/2-20 UNF
		U3	banjo bolt thread 1/2-28 UNF

5. LEVEL GAUGES SNKK (Compact Design)

Dimensions

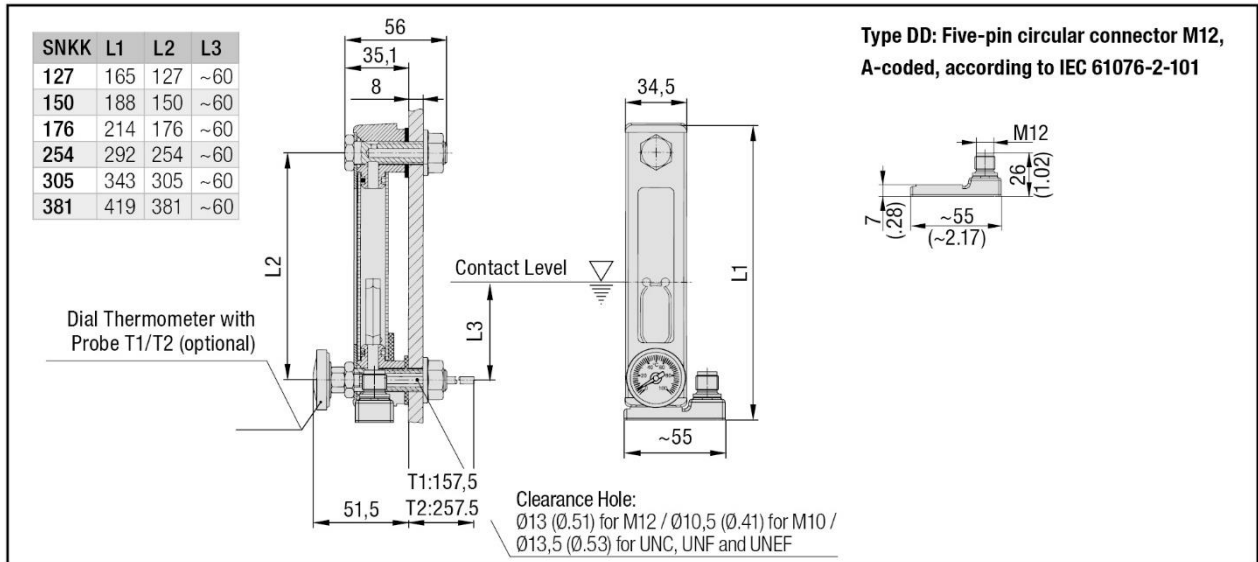

Maximum admissible tolerance for the bolt center spacing (dimension L2) according to DIN ISO 2768-f: ±0,20 mm / .008 in for all nominal sizes.

Electrical Functions

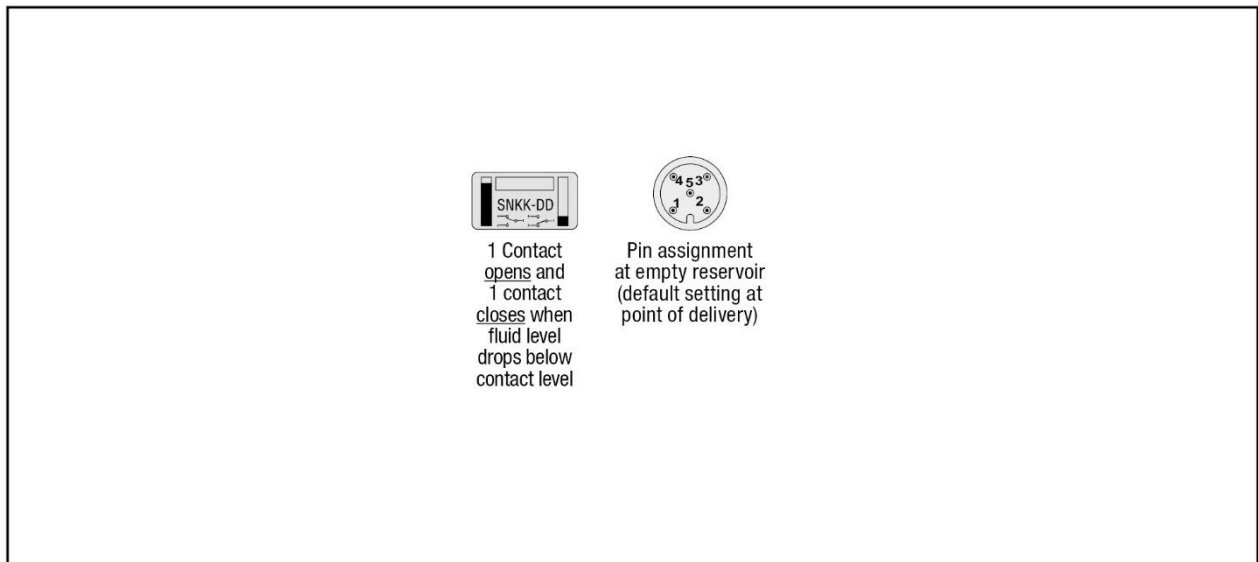

Ordering Information

SNKK-254-V-DD-O-12-O-60/2-N-123456

Hyphen

STAUFF Level Gauge (Compact design) [GB] / STAUFF Niveaumanzeiger (Kompaktdesign) [GER]	STAUFF Special number (optional)
Product range Hydraulic Accessories	STAUFF Special number according to list "Special-Number-New"
SNKK Shortcut for STAUFF Level Gauge	Additional information (optional)
	Colours according to list "Colours", special characteristics according to list "Characteristics"
STAUFF Group size	Design code (optional)
STAUFF group equals the distance between the centre of the two banjo bolts [in mm]	Slash and design code value without a blank
Seal material	Switching temperature (optional, only for Thermo Switch)
Materials according to list "Materials"	temperature value [in °C], two digits
Electrical Function	Thermo Switch / Temperature Sensor / Anti Drain valve (optional)
DD SPDT contacts, 1 contact open, 1 closed, connector M12	without without switch, sensor or anti-drain valve
Thermometer Option	O Thermo Switch, break contact (NO)
O without thermometer	C Thermo Switch, make contact (NC)
T1C Dial thermometer, 200 mm probe, °C scale	OD Thermo Switch, break contact (NO) with connector M12
T2C Dial thermometer, 300 mm probe, °C scale	CD Thermo Switch, make contact (NC) with connector M12
T1CF Dial thermometer, 200 mm probe, °C and °F scale	PT100 Thermo Switch PT100 with connector M12
T2CF Dial thermometer, 300 mm probe, °C and °F scale	DA Drainvalve Set A (one drain valve to be used with the lower banjo bolt)
Banjo Bolt size	DB Drainvalve Set B (two drain valves to be used with both banjo bolts)
12 banjo bolt thread M12	
10 banjo bolt thread M10	
U1 banjo bolt thread 1/2-13 LUNC	
U2 banjo bolt thread 1/2-20 UNF	
U3 banjo bolt thread 1/2-28 UNF	

6. TEMPERATURE SENSOR TS-SNA/SNK-PT100

The TS-SNA/SNK-PT100 temperature sensor replaces the lower banjo bolt of the STAUFF level gauge. A PT100 sensor is used with an operating temperature range of $-40^{\circ}\text{C} \dots 150^{\circ}\text{C}$. The sensor has an M12 plug connector in accordance with IEC-61076-2-101. The sensor signal can be evaluated using an SPS, an analogue measurement amplifier or the optionally available display unit TS-SNA/SNK-PT100-D.

Dimensions

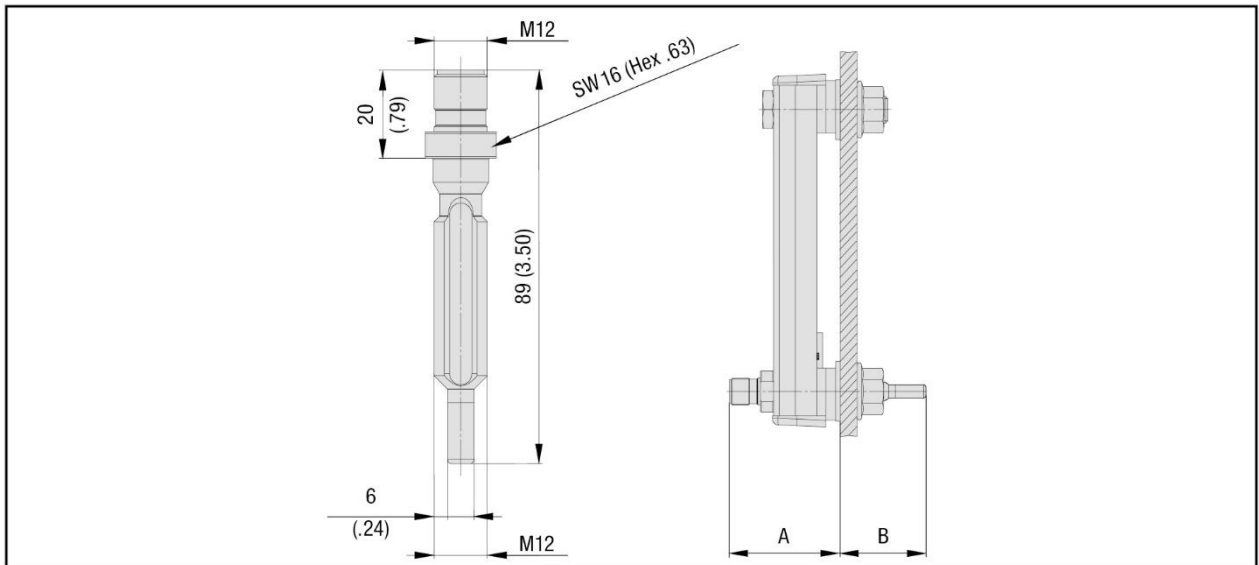

Electrical Functions

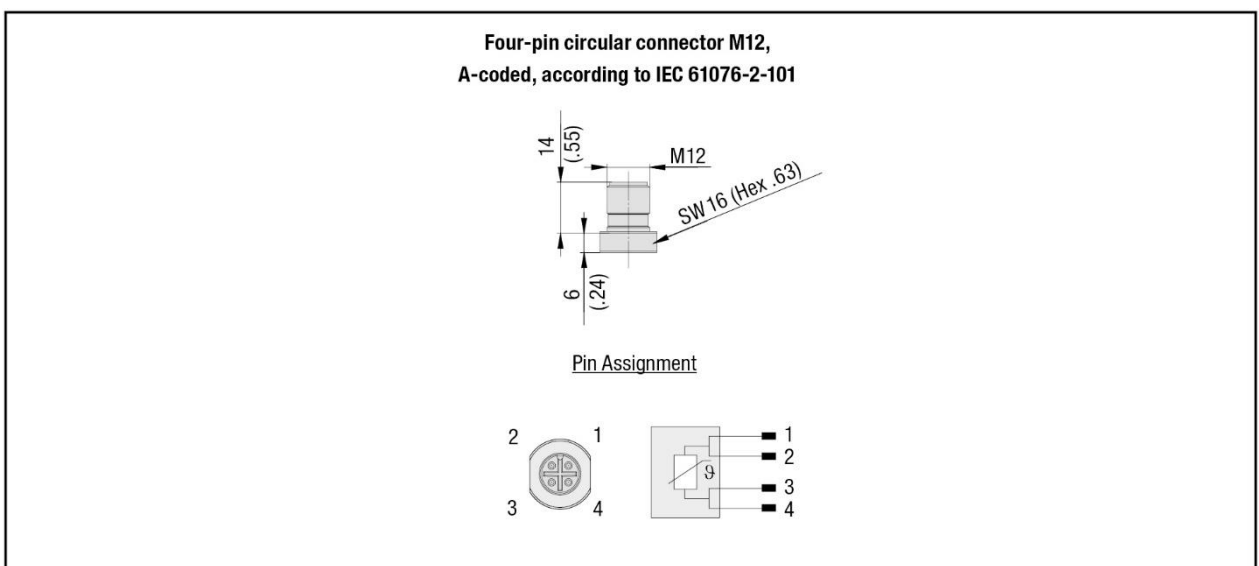

Ordering Information

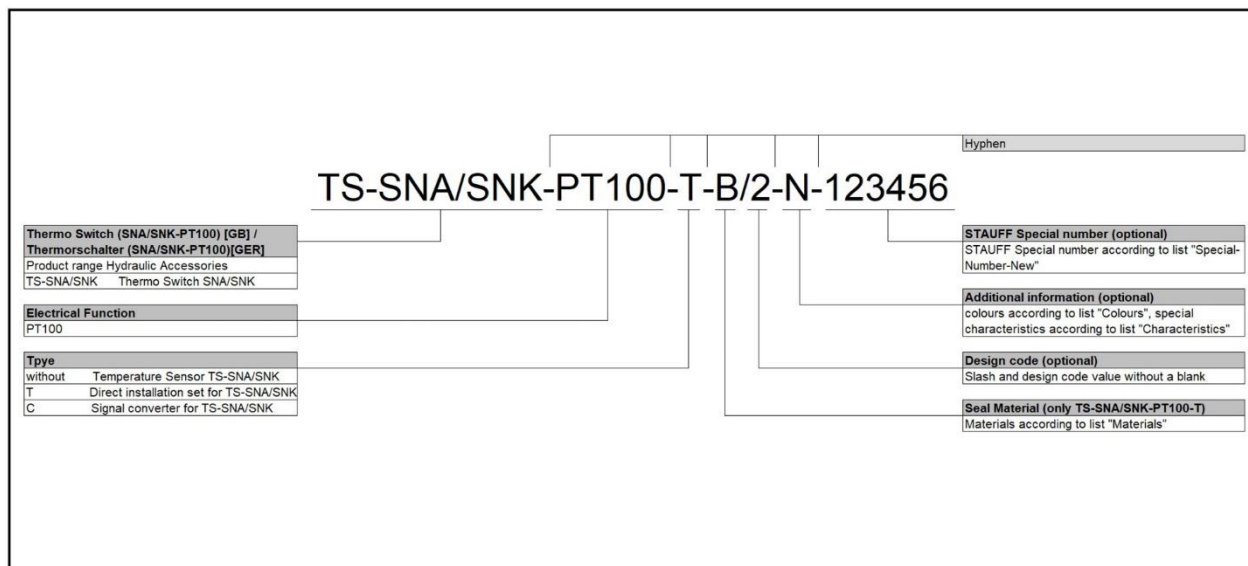

7. THERMO SWITCH TS

The TS thermo switch replaces the lower banjo bolt of the STAUFF level gauges SNA, SNK and SNKK. Available as a break contact (normally closed) or make contact (normally open) in conjunction with the respective switching temperature.

Dimensions

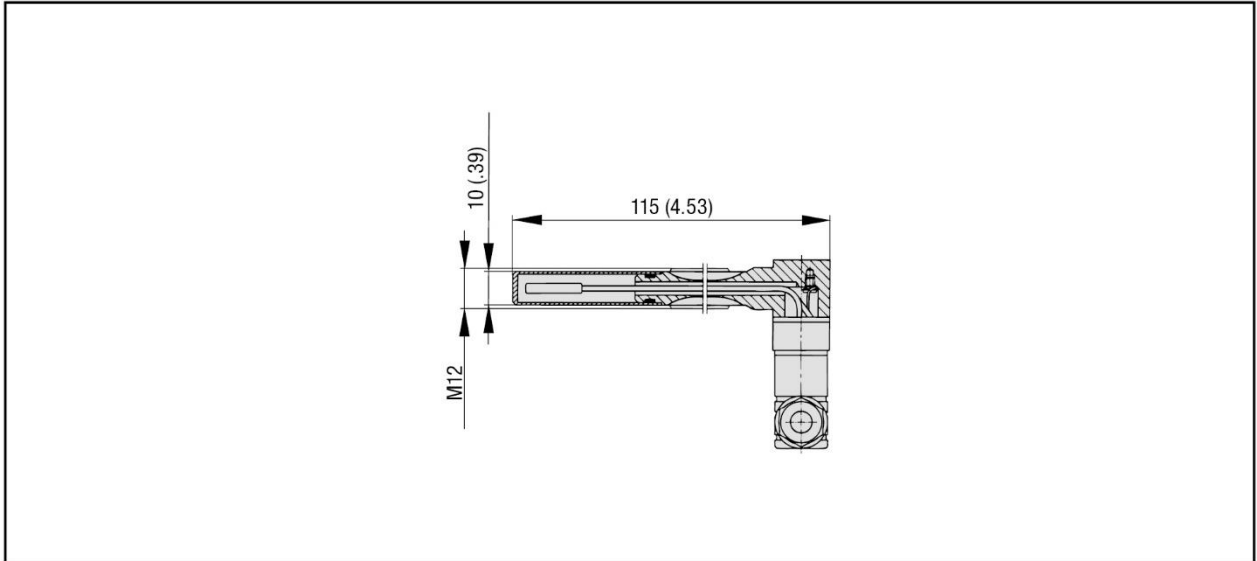

Electrical Functions

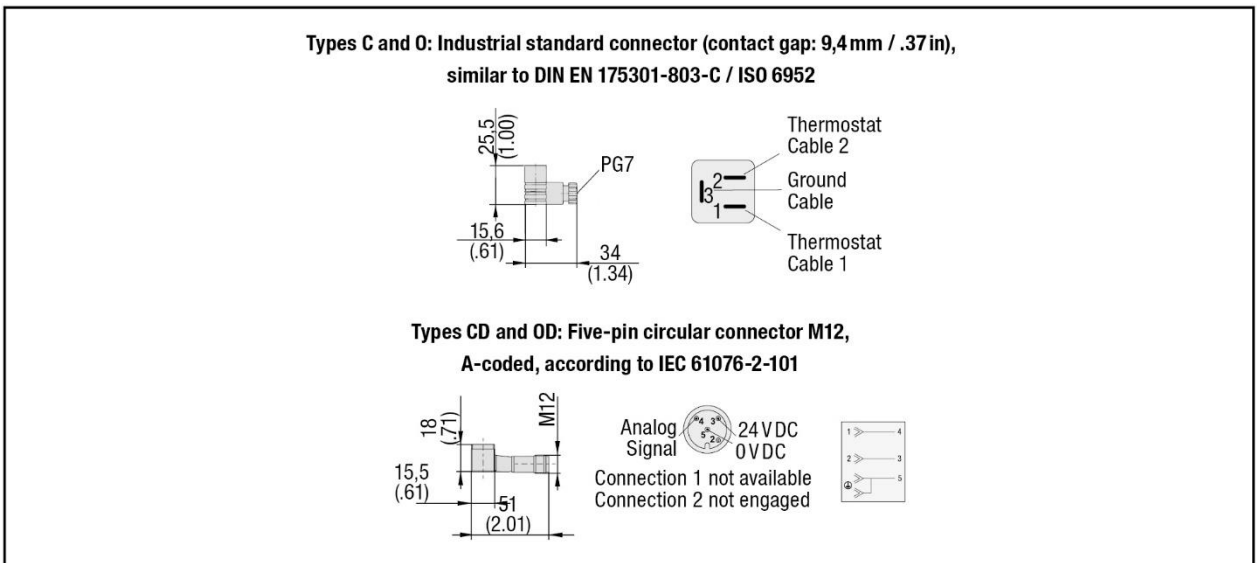

Ordering Information

