

## Leak-free tube connectors

Photos: Stauff

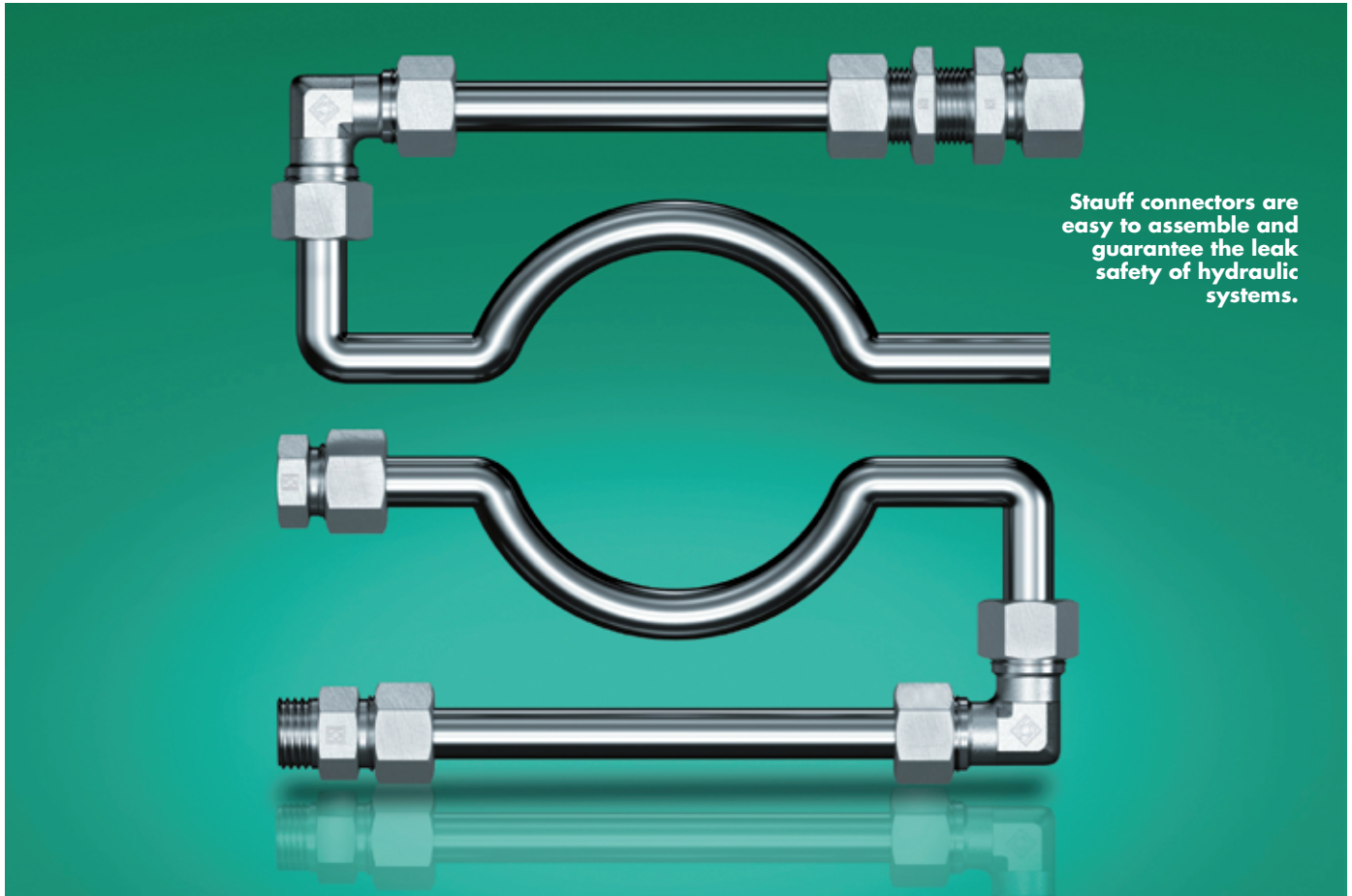

Stauff connectors are easy to assemble and guarantee the leak safety of hydraulic systems.

# Optimum assembly

**Assembly errors are the most common cause of leaking tube connectors. The simpler their assembly and maintenance, the better hydraulic line systems are protected against leaks. Stauff has now optimised its portable pre-assembly machine for 24° cutting ring fittings and is launching a new unit for manual pre-assembly. Both new products go hand in hand with simplifying handling and thus further increasing leak safety.**

*“On the assembly line, it is critical whether a hydraulic line system is leak-tight in operation”,* explains André Degen, application engineer with Stauff, the developer and producer of all components for hydraulic line systems based in the German town of Werdohl.

When he visits machine and plant manufacturers across Europe with the Stauff-Liner, he experiences at first hand how important the straightforward and intuitive assembly of tube connectors is. And this aspect is equally important in Stauff

Engineering.

Stauff supplies 24° tube connectors, among others, to connect hydraulic tubes with outside diameters of 6 to 42 mm, which are based on a cutting ring with two cutting edges arranged in tandem. Alongside its pure metallic cutting rings, Stauff also supplies the FI-WDDS range with two FKM (Viton®) soft seals positioned to remain in place.

The first part of the assembly process involves fixing the cutting ring on the prepared tube, so-called pre-assembly.

When the union nut is tightened, the two edges of the ring cut into the tube, one after the other, plastically deforming it and producing a force fit and form fit with excellent tear-out strength.

The raised material clearly visible on all sides in front of the contact face signals the end of manual pre-assembly to the user and acts as tear-off resistance.

## From manual fittings to mechanical assembly

There are various aids availa-

ble for pre-assembly, from simple fittings clamped into the vice, to mechanical pre-assembly or 100% final assembly.

Users choose the option that makes most sense for them. *“Working together with our customers is perfect when commercial, logistics and technical advice go hand in hand. Application engineers are the interface, as it were,”* continues André Degen, explaining his work.

*“The question of the angle of rotation is a decisive parameter in cutting ring assembly. To*

*what percentage is the cutting ring cut into during pre-assembly, and what percentage of the tightening path still needs to be applied in the final assembly of the connector, that is when it is in use?"*

Pure manual pre-assembly using a manual fitting works with an angle of rotation of 270° (3/4 of a revolution) once the pressure point has been reached (clearly perceptible increase in force) so that a further 90° needs to be applied – again once the pressure point has been reached.

Old and outdated assembly strategies by different manufacturers allowed for pre-assembly angles of rotation of only 50%, which then required twice the angle of rotation during final assembly and so did not achieve the pre-assembly result required according to DIN 3859-2.

*"This can be difficult in many installation situations, whether in tight spaces or with overhead fittings. Generally the assembly wrench has to be moved multiple times. This takes extra time, which is already comparatively lengthy with manual assembly, but can be justified with smaller numbers where no major investment is needed in pre-assembly."*

The entire tightening process is done using a conventional face spanner. And the union nut used is also a traditional DIN product.

### New: Portable unit for manual pre-assembly

The Stauff Press range now includes a new portable table-top unit for pressure-controlled cutting ring pre-assembly (in accordance with DIN 3859-2). The cutting ring is pre-assembled with an angle of rotation of 270° once the pressure point has been reached so that manual final assembly only requires 90°.

*André Degen: "Using our new pre-assembly unit, the pressure is manually and precisely set and read off using a high-quality Bourdon tube gauge. We recommend its use for small to medium quantities. It is beneficial with in-situ use that operation is purely manual and that no power supply is required."*

The unit comes in a sturdy steel carrying case with room for all components. All the necessary parameters for tube diameters of 6 to 42 mm (Light Series) and 6 to 38 mm (Heavy Series) in steel and stainless steel are supplied.

### Mechanical cutting ring pre-assembly

There are two versions of the Stauff Press cutting ring assembly machine available for the mechanical pre-assembly of large quantities with exceptional process reliability. The electrically-hydraulically driven Stauff Press assembly machine type SPR-PRC-MA assembles cutting rings in accordance with the standard. This sturdy table top-mounted unit is also capable of equipping tube ends with 37° flares.

There is also a second high-end solution. The Stauff Press cutting ring final assembly machine type SPR-PRC-POC provides for 100% "final" assembly of the cutting ring. Manual final tightening in the fitting body is only 30° or 1/12 revolution using the assembly

wrench.

Mechanical final assembly therefore simplifies final assembly, saves time, and minimises the risk of errors (under and over-assembly) with final tightening in the fitting body.

The most recent generation of the machine has a cloud connection with all the benefits associated with an online service: documentation, data analysis, software updates, error analysis etc.



**André Degen looks after customers throughout Europe: "It is crucial on assembly lines whether a hydraulic pipeline system is leak-tight in operation."**



**The lightweight and ergonomically designed assembly machine is located in the sturdy trolley along with all components. A spare battery and charger are included in the set.**



**Following manual pre-assembly with the portable table top-mounted unit, final assembly is only 90° once the pressure point has been reached.**

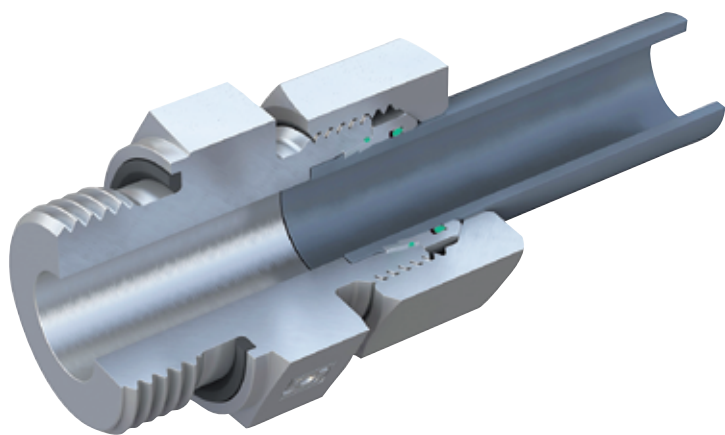

### Product update: portable cutting ring assembly machine

André Degen knows the pressure relief that a mobile assembly unit provides for personnel: *“Time and time again, hydraulic line systems are only completed when they arrive at the end customer, and maintenance and repair work is generally also done at the place of use, for instance on site. Not having to forego the benefits of mechanical pre-assembly reduces the risk of assembly errors and helps to reliably prevent leaks – regardless of the installation site.”*

A portable cutting ring assembly machine has been part of the Stauff product range from the start. This product update, which was launched in April 2024, optimises multiple steps in the assembly process, including the angle of rotation: in pre-assembly, the cutting ring is assembled to 270° once the pressure point has been reached. There is approx. 80% raised material in front of the first cut, with the result that final assembly only needs 90° final tightening.

*“It is beneficial only having to turn the wrench a quarter-turn, especially in tight spaces or when working overhead,”* explains André Degen based on his experience.

Electronic pressure setting is also new, which guarantees excellent precision **“at the touch**

**of a button”**. Over 200 assembly processes can be done with a single battery charge. A spare battery and charger are included in the set.

This lightweight and ergonomically designed assembly machine is supplied in a sturdy trolley with space for all components. Other accessories, such as fasteners for operation on a table top or on the tripod supplied, along with a shoulder strap are supplied.

All the necessary parameters for tube diameters of 6 to 42 mm (Light Series) and 6 to 38 mm (Heavy Series) in steel and stainless steel are supplied.

### “Customers feel well looked after!”

It is not just customers who feel safe when it comes to the leak-tightness of hydraulic line systems, thanks to Stauff’s practical customer care and support. Assembly personnel can also be sure that they are doing everything right from the outset. André Degen himself can look back on 20 years of experience, during which time he worked for renowned machine and plant manufacturers worldwide, installing, testing and putting into operation stationary systems at customers’ premises.

*“I have personally experienced how important every step is for the proper functioning and operation of the entire system. I can explain to a fitter the consequences that the under-*

**Connectors with soft-sealing cutting rings are particularly insensitive to vibrations, pressure peaks, and pressure shocks.**

*assembly of a tube connector will have for the entire system – and then show them how they should assemble it correctly and close any safety gaps that could lead to time-intensive and costly machine outages and environmental pollution.”*

### “Purely metallic” or “soft-sealing”?

Stauff cutting ring fittings are suitable for nominal pressures of up to 500 bar in the Light Series and up to 800 bar in the Heavy Series in accordance with ISO 8434-1/DIN 2353 on metric tube ends with outside diameters of between 6 mm and 42 mm. Alongside its pure metallic cutting rings, Stauff also supplies the FI-WDDS range with two FKM (Viton®) soft seals positioned to remain in place.

These soft-sealing cutting rings also secure the connectors against the risk of leaks, such as, for instance, by the **“settling”** of purely metallically sealed connectors caused by temperature fluctuations or serious pressure peaks and vibration loads in the system.

It also rules out **“sweating effects”** on the connecting points. Connectors with soft-sealing cutting rings are particularly insensitive to vibrations and resist pressure peaks and pressure shocks, as are caused in mobile equipment, such as construction and agricultural machines. However, they are also recommended for use in stationary industrial machines and production systems in heavy industry or in shipbuilding.

The cutting rings themselves are supplied in steel and stainless steel, and all the steel products in the StauffConnect range feature a high-quality Stauff zinc/nickel coating. With over 1,200 hours of resistance to

red rust / base metal corrosion in the salt spray chamber, according to DIN EN ISO 9227, this offers reliable corrosion protection far beyond the usual market standard.

Even after transportation, processing and installation of the components, the requirements defined in the VDMA standard sheet 24576 for tube connectors for the highest corrosion protection class K5 are significantly exceeded.

### INFORMATION:

**STAUFF Deutschland  
Walter Stauffenberg  
GmbH & Co. KG**

Im Ehrenfeld 4  
D-58791 Werdohl  
Tel.: +49/23 92/916 0  
Fax: +49/23 92/916 103  
marketing@stauff.com  
[www.stauff.com](http://www.stauff.com)