

First Material Choice for Hydrogen Applications

Electrically Conductive PA-EX Plastic Material for Pipe and Tube Clamps in the Standard Series



With the unique Polyamide-based PA-EX material, STAUFF is providing another high-performance material option for block-type pipe and tube clamps in the Standard Series according to DIN 3015-1 covering outside diameters up to 42 mm / 1 1/2 inches.

With their conductive features, pipe and tube clamps made of PA-EX contribute to minimising the potential hazards from electrostatic charges in safety-critical applications involving Hydrogen.

Leaking Hydrogen can potentially be ignited by electrical discharges (such as electrostatic discharges or contact arcs), which can lead to explosions. This is because hydrogen is highly flammable and requires only a small amount of energy to ignite.



User Benefits and Advantages

- Contribution to minimising the potential hazards from electrostatic charges (and uncontrolled discharges) in safety-critical applications and industries
- Long lasting solution with no risk of contact corrosion as it can be the case with clamps, clips and brackets made of Steel or Aluminium
- Tested and proven modular system acc. to DIN 3015-1 covering the most common metric and imperial pipe and tube diameters
- Light-weight and compact design
- Easy installation with lots of options: direct assembly, assembly with weld plates and based plates for bolting, assembly in channel rails and profiles, stacking assembly and many more

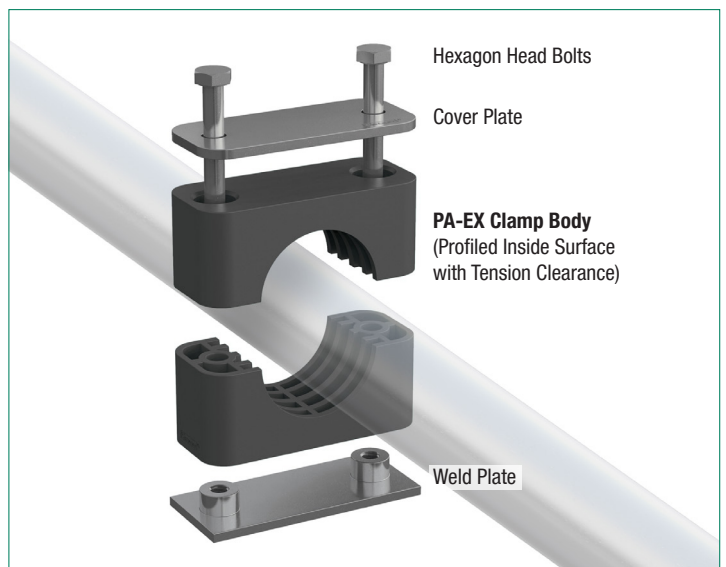

Features of PA-EX Clamps

- **Leakage resistance lower than 1Ω** acc. to IEC 60079-0
- **Surface resistance lower than 10³Ω** acc. to IEC 61340-5-1
- **No charging capabilities** acc. to IEC 60079-0



All required testing was carried out and documented independently by **TÜV Nord**.

Please do not hesitate to consult STAUFF for detailed test reports.

Please pay attention to the important notes on the right.

Important Notes

Please note: All testing was performed with properly installed clamps in the Standard Series acc. to DIN 3015-1 using unpainted metal hardware – weld plates, bolts and cover plates – and pipes or tubes, all made from stainless steel AISI 316Ti (1.4571).

Different setups, materials and surface treatments will lead to deviating measurement results.

These results are only intended to provide an initial assessment of the suitability of the component for the intended application.

It is explicitly stated that the responsibility for evaluating the measured properties in relation to the limit values defined in the relevant standards lies with the user. In addition to ATEX requirements, users must also consider international regulations and possible differences in national standards when assessing the component's compliance for their specific application and location.

Since the safety of an explosive environment does not depend on individual components alone, the entire system must always be evaluated under real operating conditions to ensure compliance with applicable regulations and safe usage.